

ELECTRIC TOOL PARTS LIST

■ SLIDING DUAL COMPOUND MITER SAW
Model C 12RSH2 / S

2019 • 06 • 18
(E1a)

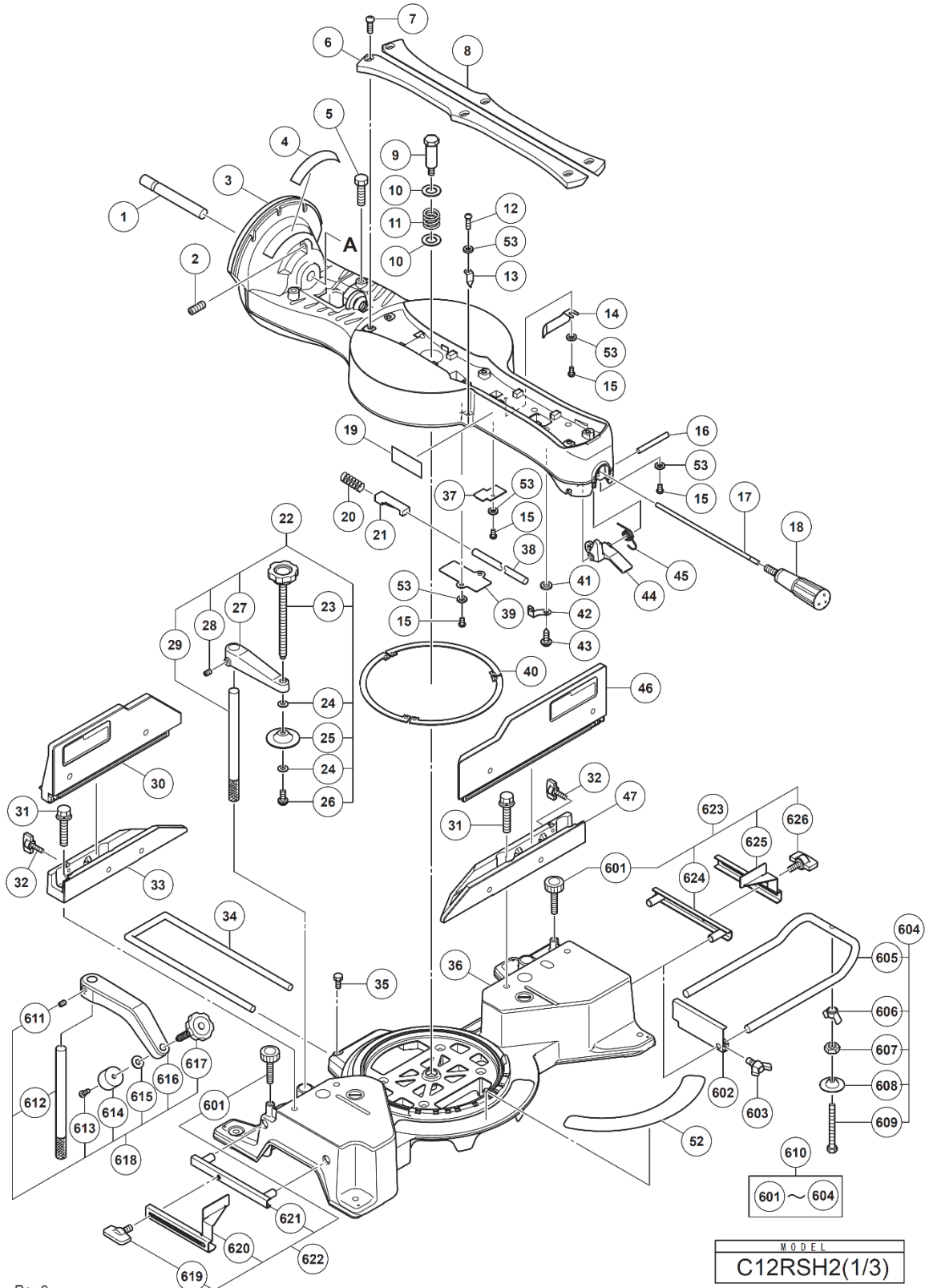

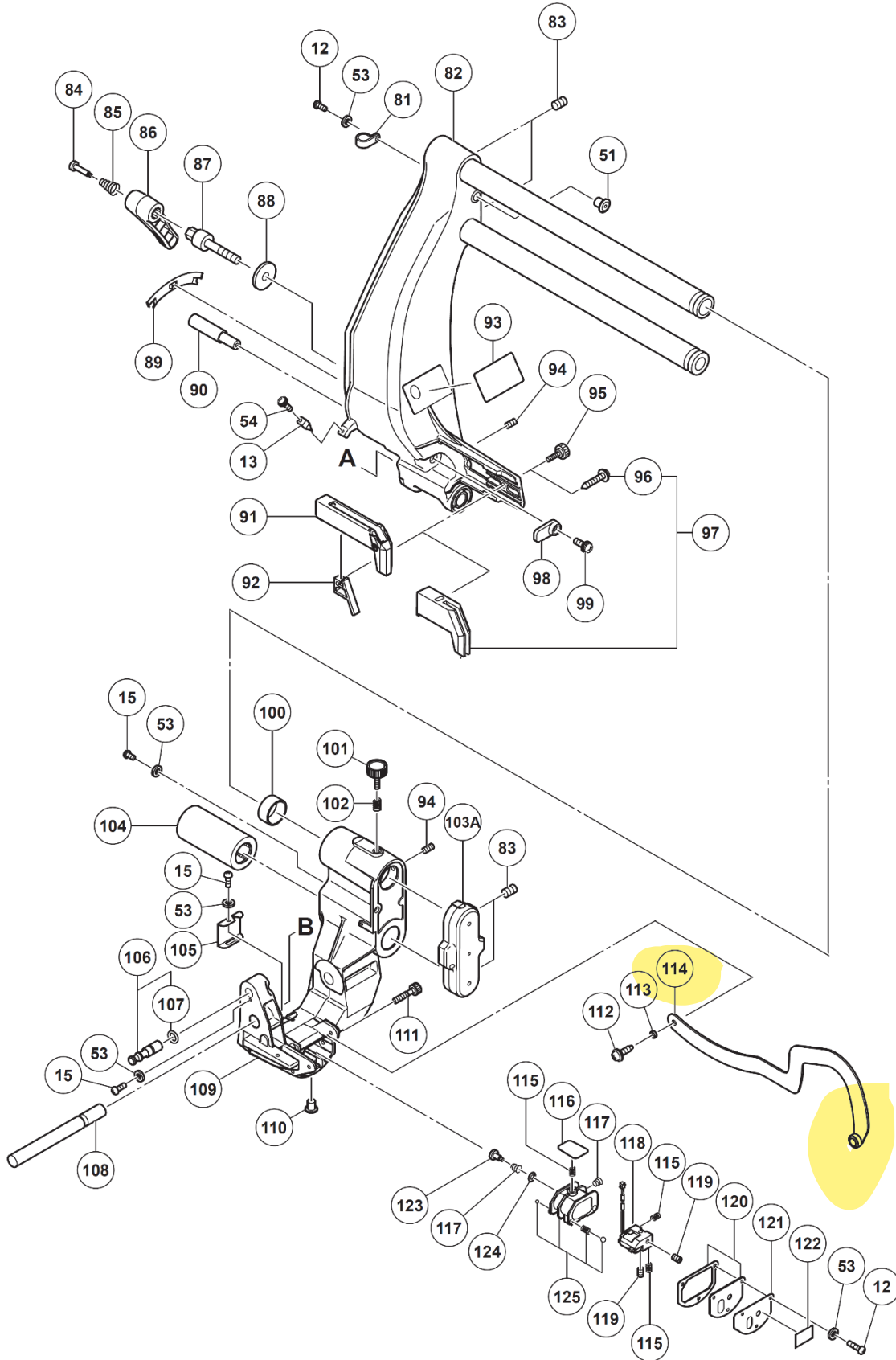

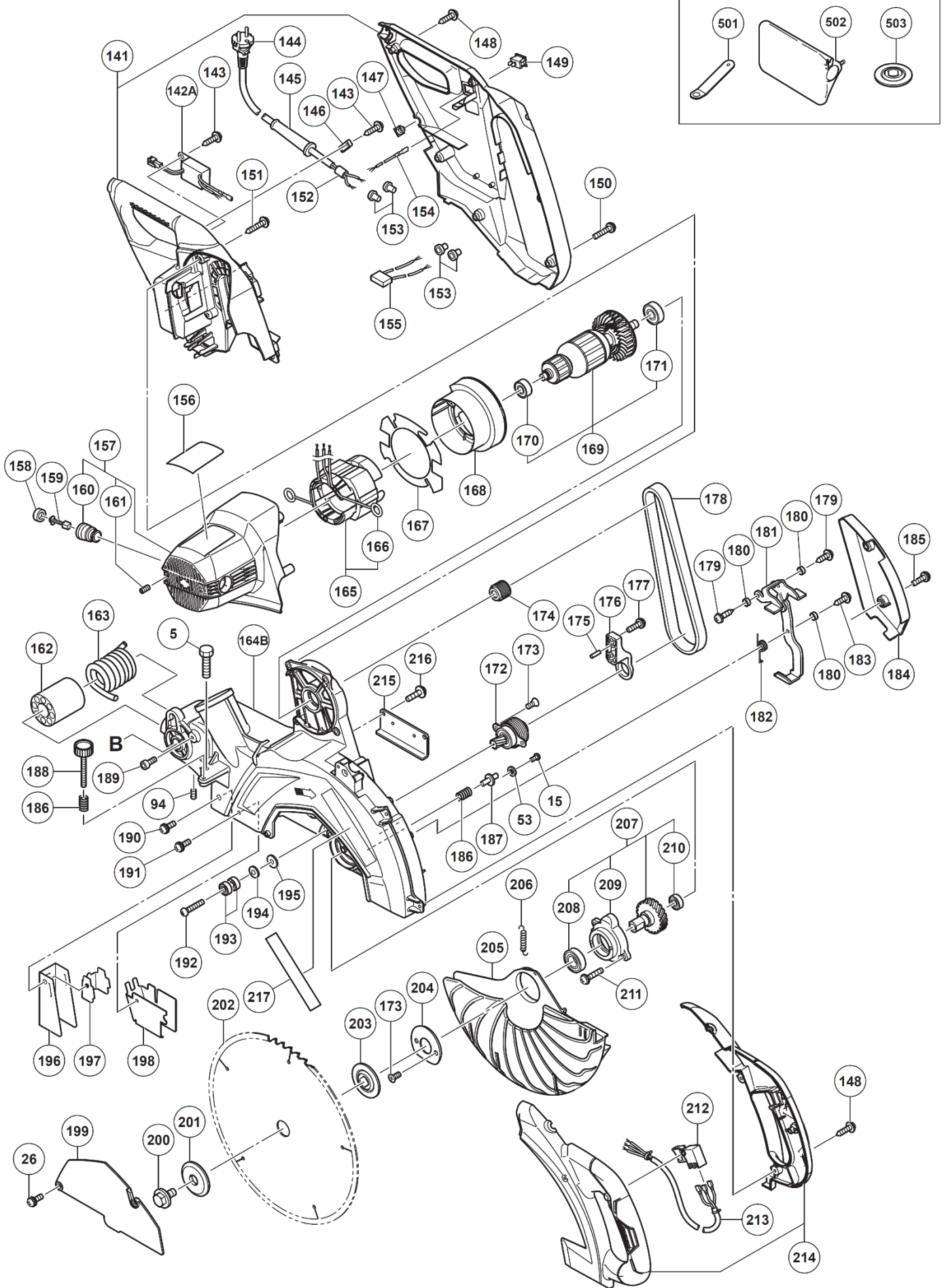

PARTS

C12RSH2 / S

ITEM NO.	CODE NO.	DESCRIPTION	NO. USED	REMARKS
1	339629	SHAFT (C) D16	1	
2	324612	NYLOCK HEX. SOCKET SET SCREW M8X16	1	
3	339633	TURN TABLE	1	
4	324416	SCALE (B)	1	
5	303409	NYLOCK BOLT M8X25	3	
6	324411	TABLE INSERT (B)	1	
7	302317	MACHINE SCREW M5X16 (BLACK)	6	
8	324410	TABLE INSERT (A)	1	
9	324401	SHAFT (B)	1	
10	955818	BOLT WASHER M16	2	
11	324402	SPRING (B)	1	
12	949217	MACHINE SCREW M4X12 (10 PCS.)	5	
13	321329	INDICATOR	3	
14	321342	SPACER (A)	1	
15	949215	MACHINE SCREW M4X8 (10 PCS.)	8	
16	321339	LEVER SHAFT	1	
17	334378	SHAFT (A)	1	
18	322283	SIDE HANDLE	1	
*19		CAUTION LABEL (C)	1	FOR USA.CAN
20	321417	SPRING (E)	1	
21	322280	STOPPER (A)	1	
22	339624	WISE ASS'Y	1	INCLUD.23-29
23	339625	KNOB BOLT M10	1	
24	996722	WASHER	2	
25	322047	WISE PLATE	1	
26	996247	MACHINE SCREW (W/WASHERS) M5X12 (BLACK)	3	
27		SCREW HOLDER	1	
28	307956	SEAL LOCK HEX. SOCKET SET SCREW M6X10	1	
29	339626	WISE SHAFT	1	
30	339657	SUB FENCE (B)	1	
31	307221	BOLT (W/WASHERS) M8X35 (BLACK)	4	
32	322959	WING BOLT M6X22	2	
33	339628	FENCE (B)	1	
34	998834	HOLDER	1	
35	949610	BOLT M6X10 (10 PCS.)	1	
36	339631	BASE ASS'Y	1	INCLUD.52
37	324395	COVER (B)	1	
38	324396	SHAFT (C) D6	1	
39	321336	PIN COVER	1	
40	324400	LINER	3	
41	949431	BOLT WASHER M5 (10 PCS.)	1	
42	321331	PLATE	1	
43	995096	MACHINE SCREW (W/WASHERS) M5X20 (BLACK)	1	
44	321338	LEVER	1	
45	321340	SPRING (D)	1	
46	339656	SUB FENCE (A)	1	
47	339627	FENCE (A)	1	
51	323606	BASE RUBBER	1	
52	370011	SCALE (A)	1	
53	949429	BOLT WASHER M4 (10 PCS.)	13	
54	935196	MACHINE SCREW (W/WASHERS) M4X12 (BLACK)	2	
*81	948193	NYLON CLIP	1	FOR USA.CAN.UAE (110V).GBR (110V)
*82	339732	HOLDER (A) ASS'Y	1	INCLUD.51.83.93.103
83	961554	HEX. SOCKET SET SCREW M8X10	4	
84	339621	CLUTCH SCREW	1	
85	339620	CLUTCH SPRING	1	
86	339619	CLAMP LEVER	1	
87	339618	BOLT (LEFT HAND) D10	1	
88	339622	WASHER	1	
89	339623	LINER (A)	1	
90	324420	SET PIN (A)	1	
*91	326828	GUARD	1	SINCE 01.2019 FOR USA.CAN.MODEL(S)
*92	331845	GUARD HOLDER	1	SINCE 01.2019 FOR USA.CAN.MODEL(S)

PARTS

C12RSH2 / S

ITEM NO.	CODE NO.	DESCRIPTION	NO. USED	REMARKS
93		CAUTION LABEL (B)	1	
94	307956	SEAL LOCK HEX. SOCKET SET SCREW M6X10	3	
*95	998879	KNOB BOLT	1	SINCE 01.2019 FOR USA.CAN.MODEL(S)
*96	305558	TAPPING SCREW (W/FLANGE) D5X25 (BLACK)	1	FOR USA.CAN
*97	324372	GUARD ASS'Y	1	TILL 12.2018 FOR USA.CAN
98	324421	GRIP	1	
99	307294	MACHINE SCREW (W/WASHERS) M5X16 (BLACK)	1	
100	324415	BUSHING	1	
101	324418	KNOB BOLT M6X25	1	
102	947859	LOCK SPRING	1	
103A	334458	SUPPORT	1	
104	324414	BALL BUSHING	1	
105	320183	COVER	1	
106	324419	STOPPER PIN ASS'Y	1	INCLUD.107
107	872645	O-RING (P-9)	1	
108	324387	HINGE SHAFT (A)	1	
109	324467	HINGE (A)	1	
110	312672	BASE RUBBER	1	
111	319270	ADJUSTER	1	
112	949237	MACHINE SCREW M5X12 (10 PCS.)	1	
113	303854	SPACER	1	
*114	324376	LINK	1	
115	319267	SPRING	3	
116	319268	PLATE (B)	1	
117	305179	CLUTCH SPRING	2	
118	329863	LASER MARKER	1	
119	319541	SEAL LOCK HEX. SOCKET SET SCREW M5X6	2	
120	319271	COVER (A)	1	
121	322291	PLATE (A)	1	
122		CAUTION LABEL (J)	1	
123	305180	CLUTCH SCREW	1	
124	962614	ADJUSTING WASHER (B) T0.5	1	
125	319269	HOLDER (B)	1	
141	339644	HANDLE (L).(R) SET	1	
*142A	371119	SWITCHING POWER SUPPLY	1	FOR USA.CAN
143	984750	TAPPING SCREW (W/FLANGE) D4X16	3	
*144	500453Z	CORD	1	(CORD ARMOR D10.1) FOR USA.CAN
145	938051	CORD ARMOR D10.1	1	
146	937631	CORD CLIP	1	
147	319349	CORD BUSH	1	
148	301653	TAPPING SCREW (W/FLANGE) D4X20 (BLACK)	7	
149	319503	SWITCH (W/COVER)	1	
150	880734	MACHINE SCREW (W/WASHERS) M5X25 (BLACK)	4	
151	305558	TAPPING SCREW (W/FLANGE) D5X25 (BLACK)	4	
*153	959141	CONNECTOR 50092 (10 PCS.)	4	
154	324458	INTERNAL WIRE (C)	1	
156		NAME PLATE	1	
157	339643	HOUSING ASS'Y	1	INCLUD.160.161
158	945161	BRUSH CAP	2	
*159	999038	CARBON BRUSH (1 PAIR)	2	FOR 110V-120V
160	938241	BRUSH HOLDER	2	
161	938477	HEX. SOCKET SET SCREW M5X8	2	
162	324388	SLEEVE	1	
163	310898	SPRING	1	
*164C	375140	GEAR CASE	1	FOR USA.CAN.MODEL(S)
*165	340924C	STATOR ASS'Y (A) 120V	1	INCLUD.166
166	937623	BRUSH TERMINAL	2	
167	339734	END PLATE	1	
168	339642	FAN GUIDE	1	
*169	361021B	ARMATURE ASS'Y 110V-120V	1	INCLUD.170.171.174
170	6000VV	BALL BEARING 6000VVCMP52L	1	
171	6201VV	BALL BEARING 6201VV	1	
172	339641	PINION SET	1	
173	949322	FLAT HD. SCREW M4X10 (10 PCS.)	4	
174	324443	PULLEY (A)	1	

