

## ELECTRIC TOOL PARTS LIST

SLIDING COMPOUND MITER SAW

2024 • 02 • 22

Model C 12RSH3

(E1)

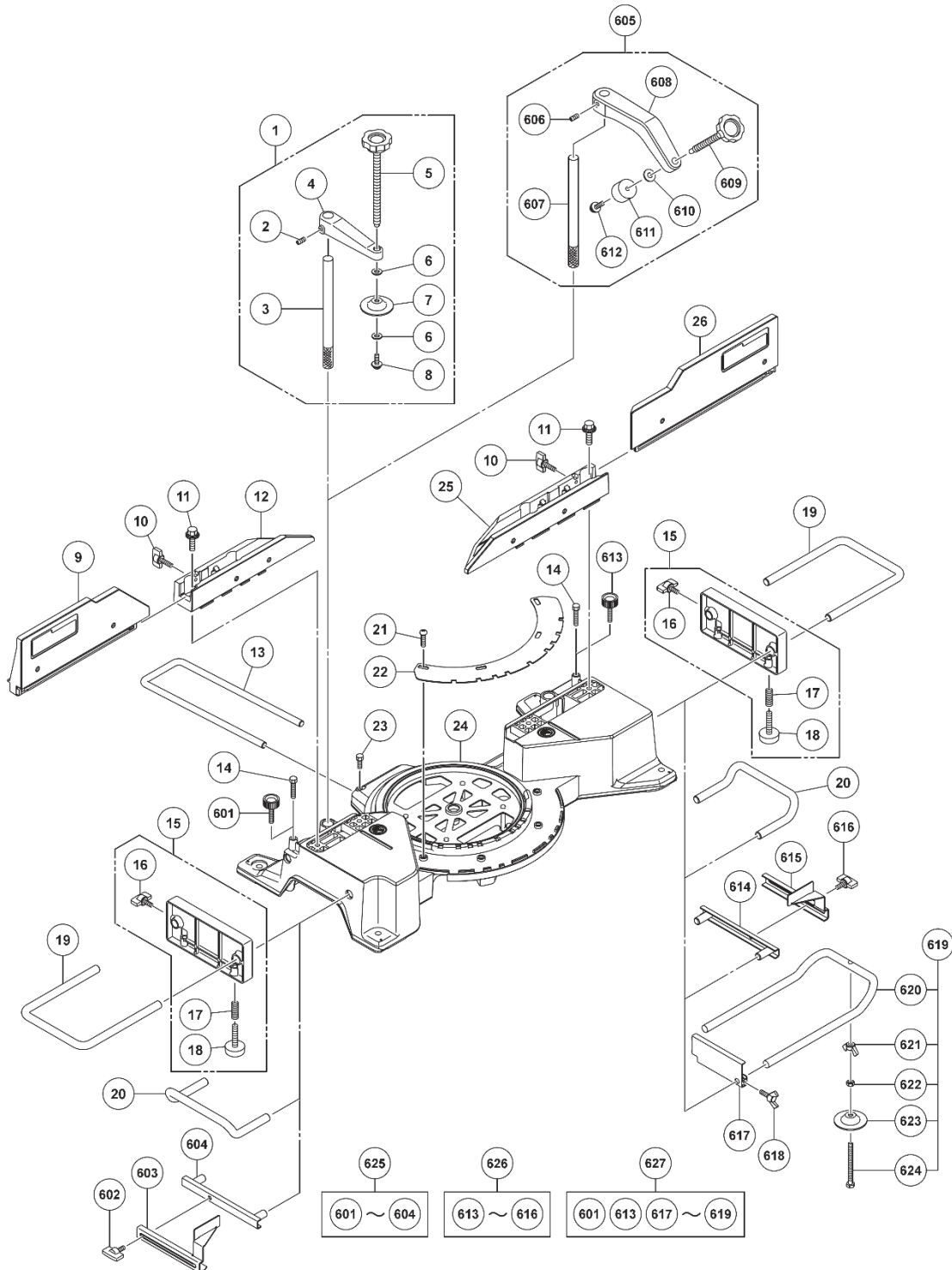

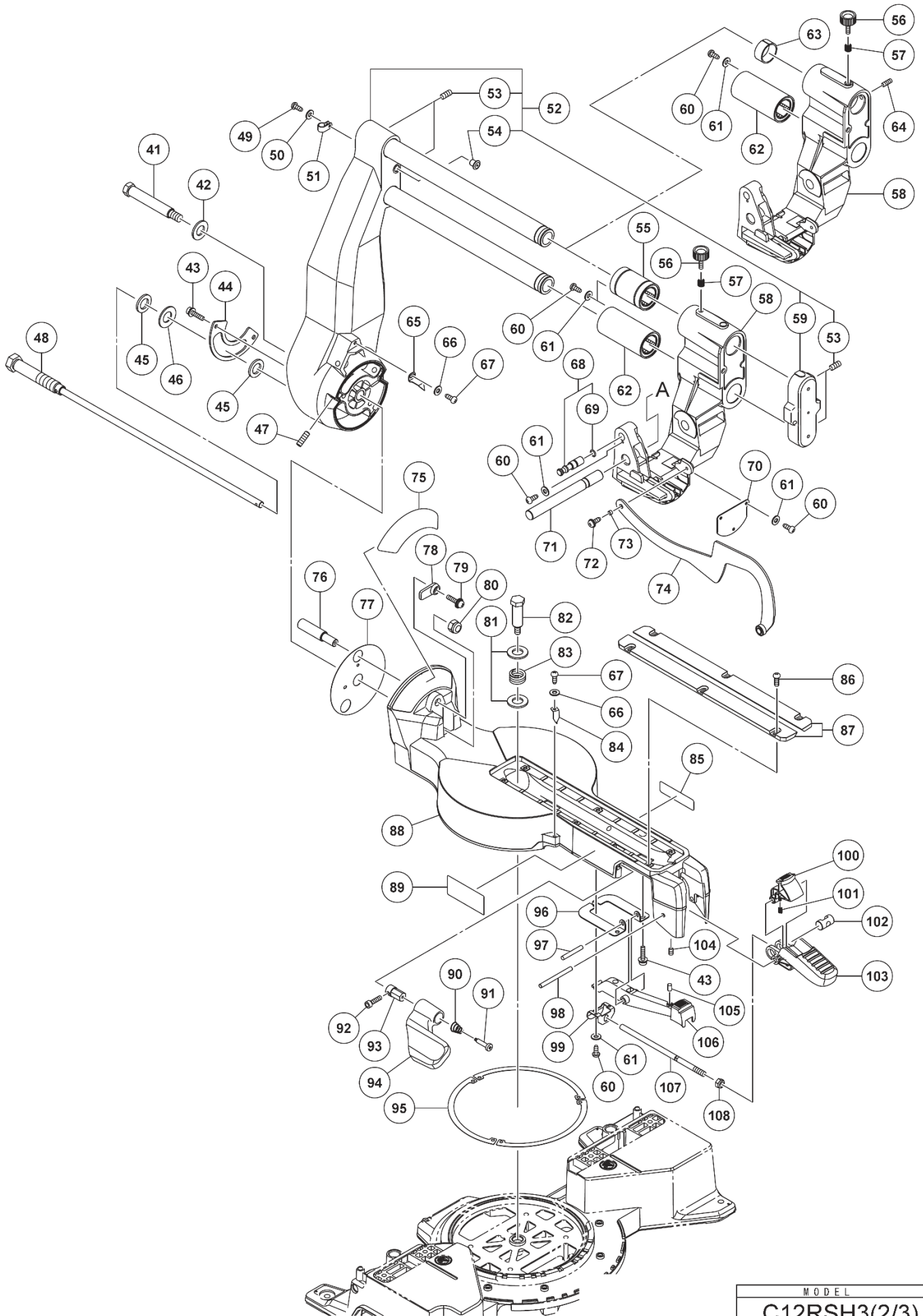

Rev.1

MODEL  
C12RSH3(2/3)

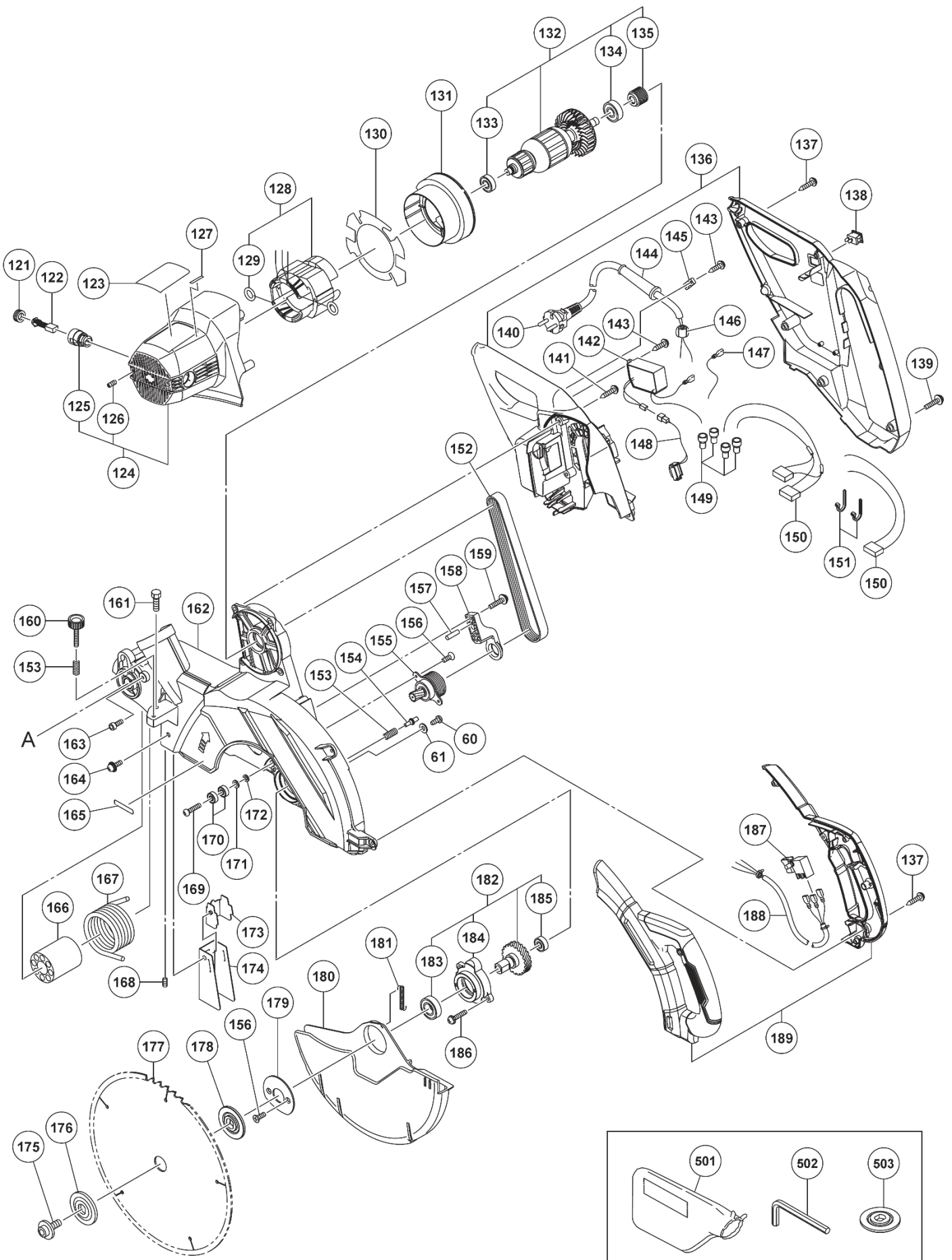

## PARTS

C12RSH3

ITEM NO.	CODE NO.	DESCRIPTION	NO. USED	REMARKS
1	339624	WISE ASS'Y	1	INCLUD.2-8
2	307956	SEAL LOCK HEX. SOCKET SET SCREW M6X10	1	
3	339626	WISE SHAFT	1	
4		SCREW HOLDER	1	
5	339625	KNOB BOLT M10	1	
6	996722	WASHER	2	
7	322047	WISE PLATE	1	
8	996247	MACHINE SCREW (W/WASHERS) M5X12 (BLACK)	1	
9	380821	SUB FENCE (B)	1	
10	322959	WING BOLT M6X22	2	
11	307221	BOLT (W/WASHERS) M8X35 (BLACK)	4	
12	380819	FENCE (B)	1	
13	376730	HOLDER	1	
**14	375142	BOLT M6X30	2	FOR.NZL.SAF.TUR.U.SA.CAN
**20	380332	SIDE HOLDER	2	FOR USA.CAN
21	380805	SPECIAL SCREW M6	4	
22	380803	MITER SCALE	1	
23	949610	BOLT M6X10 (10 PCS.)	1	
24	380806	BASE	1	
25	380818	FENCE (A)	1	
26	380820	SUB FENCE (A)	1	
41	380850	SPECIAL BOLT M12	1	
42	955818	BOLT WASHER M16	1	
43	307354	HEX. SOCKET HD. BOLT (W/WASHERS) M6X16	4	
44	380847	BRAKE PLATE	1	
45	380848	WASHER D18	2	
46	380849	BELLEVILLE SPRING D18	1	
47	324612	NYLOCK HEX. SOCKET SET SCREW M8X16	3	
48	380846	SPECIAL BOLT SET M18	1	
49	949217	MACHINE SCREW M4X12 (10 PCS.)	1	
50	949429	BOLT WASHER M4 (10 PCS.)	1	
**51	948193	NYLON CLIP	1	FOR GBR(110V).USA.CAN
**52	380825	HOLDER (A) ASS'Y	1	INCLUD.53.54.59 FOR USA.CAN
53	961554	HEX. SOCKET SET SCREW M8X10	4	
54	323606	BASE RUBBER	1	
56	324418	KNOB BOLT M6X25	1	
57	947859	LOCK SPRING	1	
**58	324467	HINGE (A)	1	FOR USA.CAN
59	334458	SUPPORT	1	
**60	949215	MACHINE SCREW M4X8 (10 PCS.)	8	FOR USA.CAN
**61	949429	BOLT WASHER M4 (10 PCS.)	8	FOR USA.CAN
62	324414	BALL BUSHING	1	
**63	324415	BUSHING	1	FOR USA.CAN
**64	307956	SEAL LOCK HEX. SOCKET SET SCREW M6X10	1	FOR USA.CAN
65	380852	INDICATOR	1	
66	949429	BOLT WASHER M4 (10 PCS.)	2	
67	949217	MACHINE SCREW M4X12 (10 PCS.)	2	
68	324419	STOPPER PIN ASS'Y	1	INCLUD.69
69	872645	O-RING (P-9)	1	
70	324058	HINGE COVER	1	
71	324387	HINGE SHAFT (A)	1	
72	949237	MACHINE SCREW M5X12 (10 PCS.)	1	
73	380842	SPACER	1	
74	380841	LINK	1	
75	380816	BEVEL SCALE	1	
76	324420	SET PIN (A)	1	
77	380851	LINER	1	
78	324421	GRIP	1	
79	307294	MACHINE SCREW (W/WASHERS) M5X16 (BLACK)	1	
80	371741	NYLON NUT M12	1	
81	955818	BOLT WASHER M16	2	
82	324401	SHAFT (B)	1	
83	324402	SPRING (B)	1	
84	318927	INDICATOR (A)	1	

## PARTS

C12RSH3

**85		WARNING LABEL (FRA)	1	
86	380824	MACHINE SCREW M5X12 (BLACK)	6	
87	380817	TABLE INSERT	2	
88	380808	TURN TABLE	1	
89		OPERATION LABEL	1	
90	339620	CLUTCH SPRING	1	
91	339621	CLUTCH SCREW	1	
92	949821	HEX. SOCKET HD. BOLT M5X16 (10 PCS.)	1	
93	380845	JOINT (A)	1	
94	380844	BEVEL LOCK HANDLE	1	
95	324400	LINER	3	
96	380810	SPRING PLATE	1	
97	983564	PIN D6	1	
98	321339	LEVER SHAFT	1	
99	380809	SPACER (A)	1	
100	380813	DETENT LEVER	1	
101	381530	SPRING	1	
102	380814	LOCK SHAFT (A)	1	
103	380812	MITER LOCK HANDLE	1	
104	319541	SEAL LOCK HEX. SOCKET SET SCREW M5X6	1	
105	946362	BEARING LOCK	1	
106	380811	POSITIVE STOP LEVER	1	
107	380815	LOCK SHAFT (B)	1	
108	371739	NYLON NUT M8	1	
121	945161	BRUSH CAP	2	
**122	999038	CARBON BRUSH (1 PAIR)	2	FOR 110V-120V
123		NAME PLATE	1	
124	339643	HOUSING ASS'Y	1	INCLUD.125.126
125	938241	BRUSH HOLDER	2	
126	938477	HEX. SOCKET SET SCREW M5X8	2	
**128	340924C	STATOR ASS'Y (A) 120V	1	INCLUD.129
129	937623	BRUSH TERMINAL	2	
130	339734	END PLATE	1	
131	339642	FAN GUIDE	1	
**132	361021B	ARMATURE ASS'Y 110V-120V	1	INCLUD.133-135
133	6000VV	BALL BEARING 6000VVCMP2L	1	
134	6201VV	BALL BEARING 6201VV	1	
135	378182	PULLEY (A)	1	
**136	380834M	HANDLE (L).(R) SET	1	FOR USA.CAN
137	301653	TAPPING SCREW (W/FLANGE) D4X20 (BLACK)	8	
139	880734	MACHINE SCREW (W/WASHERS) M5X25 (BLACK)	4	
**140	500453Z	CORD	1	(CORD ARMOR D10.1) FOR USA.CAN
141	305558	TAPPING SCREW (W/FLANGE) D5X25 (BLACK)	4	
**142	380831	POWER SUPPLY	1	FOR USA.CAN
143	984750	TAPPING SCREW (W/FLANGE) D4X16	3	
144	938051	CORD ARMOR D10.1	1	
145	937631	CORD CLIP	1	
148	380832	LED	1	
149	959141	CONNECTOR 50092 (10 PCS.)	4	
152	324427	BELT (200H10) 16X508	1	
153	988821	LOCK SPRING	2	
154	307732	STOPPER PIN	1	
155	339641	PINION SET	1	
156	949322	FLAT HD. SCREW M4X10 (10 PCS.)	4	
157	983545	NEEDLE ROLLER	2	
158	325259	BEARING HOLDER (B)	1	
159	995096	MACHINE SCREW (W/WASHERS) M5X20 (BLACK)	2	
160	961468	KNOB BOLT M6X37	1	
161	303409	NYLOCK BOLT M8X25	1	
**162	380833M	GEAR CASE	1	FOR USA.CAN
163	877839	SEAL LOCK HEX. SOCKET HD. BOLT M5X10	1	
164	935196	MACHINE SCREW (W/WASHERS) M4X12 (BLACK)	1	
166	324388	SLEEVE	1	
167	310898	SPRING	1	
168	307956	SEAL LOCK HEX. SOCKET SET SCREW M6X10	1	
169	949260	MACHINE SCREW M6X25 (10 PCS.)	1	
170	606ZZM	BALL BEARING 606VV	2	

**PARTS**

C12RSH3

171	949455	SPRING WASHER M6 (10 PCS.)	1	
172	949425	WASHER M6 (10 PCS.)	1	
173	339648	GUIDE HOLDER	1	
174	339649	DUST GUIDE	1	
175	380840	LEFT HEX. SOCKET BOLT M10	1	
**176	339652	WASHER (B)	1	
**177		TCT SAW BLADE 305MM-D25.4 HOLE-NT32	1	
**178	324452	WASHER (A)	1	
179	307731	COVER	1	
180	380843	LOWER GUARD	1	
181	375141	RETURN SPRING (B)	1	
182	324438	SPINDLE ASS'Y	1	INCLUD.183-185
183	327694	BALL BEARING 6003VVCM (NYLON RETAINER)	1	
184	324439	BEARING HOLDER	1	
185	333945	BALL BEARING 608VV	1	
186	333963	MACHINE SCREW (W/SP. WASHER) M5X20	2	
**187	375115	SWITCH (3P FASTON TYPE)	1	FOR USA.CAN
188	339636	INTERNAL WIRE (A)	1	
**189	380837	SWITCH HANDLE (L).(R) SET	1	

## STANDARD ACCESSORIES

NT1850DG

ITEM NO.	CODE NO.	DESCRIPTION	NO. USED	REMARKS
**501	322955M	DUST BAG (BLACK)	1	FOR USA.CAN
502	955857	HEX. BAR WRENCH 8MM	1	

## OPTIONAL ACCESSORIES

ITEM NO.	CODE NO.	DESCRIPTION	NO. USED	REMARKS
601	960017	KNOB BOLT M6X32	1	
602	301806	WING BOLT M6X15	1	
603		CROWN MOLDING STOPPER (L)	1	
604	321390	CROWN MOLDING STOPPER HOLDER	1	
605	339660	WISE (B) ASS'Y	1	INCLUD.606-612
606	307956	SEAL LOCK HEX. SOCKET SET SCREW M6X10	1	
607	339626	WISE SHAFT	1	
608	339661	SCREW HOLDER (B)	1	
609	339662	KNOB BOLT M10	1	
610	322677	WASHER (H)	1	
611	964851	BASE RUBBER	1	
612	304043	MACHINE SCREW (W/WASHERS) M4X10 (BLACK)	1	
613	960017	KNOB BOLT M6X32	1	
614	321390	CROWN MOLDING STOPPER HOLDER	1	
615		CROWN MOLDING STOPPER ®	1	
616	301806	WING BOLT M6X15	1	
617	974561	STOPPER	1	
618	949404	WING BOLT M6X20 (10 PCS.)	1	
619	324464	HOLDER ASS'Y	2	INCLUD.620-624
620	321549	HOLDER	2	
621	949313	WING NUT M6 (10 PCS.)	2	
622	949556	NUT M6 (10 PCS.)	2	
623	322047	WISE PLATE	2	
624	324412	HIGH TENSION BOLT M6X95	2	
625	339730	CROWN MOLDING STOPPER (L) ASS'Y	1	INCLUD.601-604
626	339731	CROWN MOLDING STOPPER (R) ASS'Y	1	INCLUD.613-616
627	324369	EXTENSION HOLDER AND STOPPER	1	INCLUD.613.617-619